

# Micrometer

The origin of Mitutoyo's trustworthy brand of small tool instruments

## Outside Micrometers SERIES 102

- Heat-insulated frame.
- Cut-away frame (behind anvil) for measuring in hard-to-reach places.
- Equipped with Ratchet Stop for constant measuring force.
- Measuring faces: Carbide.
- In addition to standard specification, a non-rotating spindle type tooth thickness micrometer (refer to page B-33 for details) is also available.



Ratchet stop  
**102-301**

## SPECIFICATIONS

### Metric

Order No.	Range (mm)	Graduation (mm)	Maximum permissible error $J_{MPE}$ ( $\mu\text{m}$ )	Flatness ( $\mu\text{m}$ )	Parallelism ( $\mu\text{m}$ )	Constant-force device
<b>102-301</b>	0 - 25	0.01	$\pm 2$	0.6	2	Ratchet stop
<b>102-302</b>	25 - 50					
<b>102-303</b>	50 - 75					
<b>102-304</b>	75 - 100					

### Metric

Order No.	Range (mm)	Graduation (mm)	Maximum permissible error $J_{MPE}$ ( $\mu\text{m}$ )	Flatness ( $\mu\text{m}$ )	Parallelism ( $\mu\text{m}$ )	Constant-force device
<b>102-311</b>	0 - 25	0.001	$\pm 1$	0.3	1	Ratchet stop
<b>102-313</b>						Friction thimble
<b>102-312</b>	25 - 50					Ratchet stop

### Inch

Order No.	Range (in)	Graduation (in)	Maximum permissible error $J_{MPE}$ (in)	Flatness (in)	Parallelism (in)	Constant-force device
<b>102-327-10</b>	0 - 1	0.0001	$\pm 0.0001$	0.000024	0.00008	Ratchet stop
<b>102-329-10</b>						Friction thimble
<b>102-328-10</b>	1 - 2	0.0001	$\pm 0.0001$	0.000024	0.00008	Ratchet stop
<b>102-330-10</b>						Friction thimble
<b>102-331-10</b>	2 - 3					Ratchet stop
<b>102-332-10</b>	3 - 4		$\pm 0.00015$		0.00012	Ratchet stop

### Metric Micrometer set

Order No.	Range (mm)	Models included
<b>102-911-40</b>	0 - 100 (Four micrometers per set)	<ul style="list-style-type: none"> <li>• <b>102-301</b></li> <li>• <b>102-302</b></li> <li>• <b>102-303</b></li> <li>• <b>102-304</b></li> <li>• 3 micrometer standards</li> </ul>

## DIMENSIONS

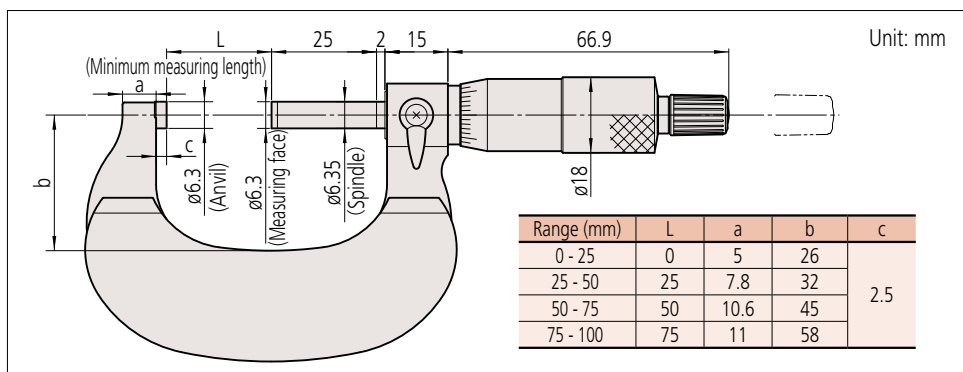

An inspection certificate is supplied as standard. Refer to page U-9 for details.

## Common specifications

- Measuring force: 5 to 10 N
- Standard accessories: Reference bar, 1 pc. (except for measuring range 0 to 25 mm models)
- Spanner (**301336**), 1 pc. (for measuring range 0 to 25 mm/25 to 50 mm models)
- Spanner (**200877**), 1 pc. (for measuring range 50 to 75 mm/75 to 100 mm models)

### Ratchet stop type



### Friction thimble type

